

1986 Pontiac 6000 STE Low Pitch Noise From Rear Disc Brakes

A low pitched moaning noise may be heard from the rear brakes on some Pontiac 6000 STE vehicles under light braking. The noise itself is a low frequency, unlike brake squeal and may also be noticed as a vibration felt through the body of the vehicle.

In order to eliminate this condition, it will be necessary to add a dampener kit, available from G.M. (Part Number 18014586), which consists of two dampener weights, two caliper brake levers (left and right), and two parking brake lever nuts.

Installation requires removal of the existing lever return spring. Next, install the replacement lever re-attach the parking brake lever return spring and install the dampener to the parking brake lever (Figure 1). When installing the dampener **DO NOT** use a wrench on the hex head directly behind the dampener, (between the dampener weight and parking brake lever: Arrow in Figure 2) as this could cause damage to the dampener assembly.

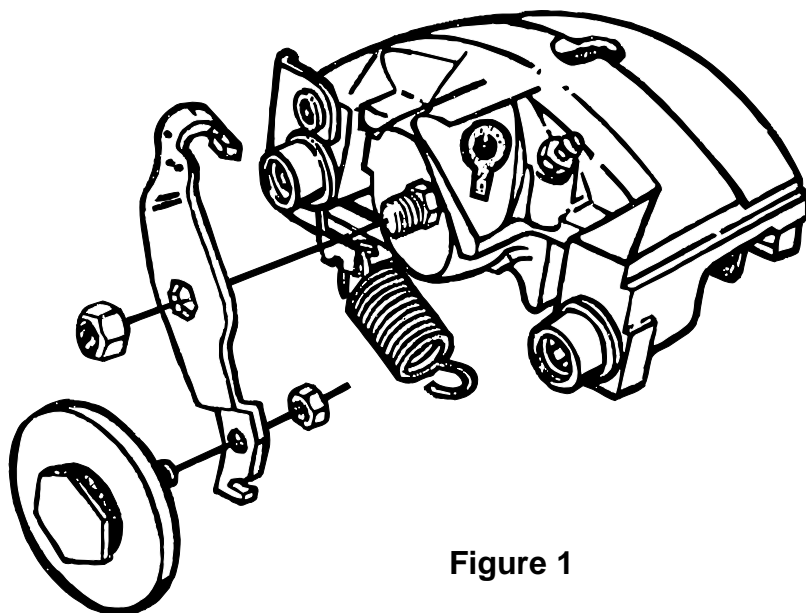

Figure 1

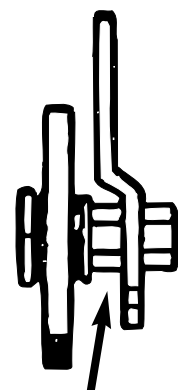

Figure 2